

ALL INFORMATION CONTAINED IN THIS DOCUMENT SHOULD BE USED FOR REFERENCE PURPOSES ONLY & ARE SUBJECT TO CHANGE WITHOUT PRIOR NOTIFICATION. ALSO, THIS DOCUMENT IS CONSIDERED PROPRIETARY & THE SOLE PROPERTY OF CRYOMECH, INC. & SHOULD NOT BE REPRODUCED IN ANY MANNER WITHOUT PRIOR WRITTEN APPROVAL.

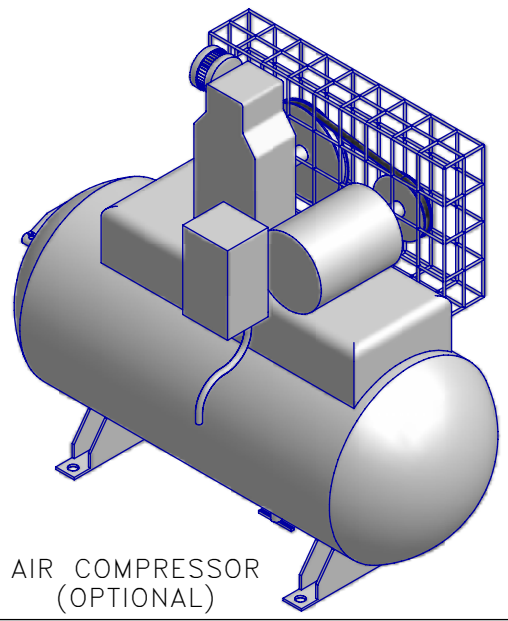

POWER CORD  
CP830 COMPRESSOR PACKAGE (AIR COOLED)

COLD HEAD MOTOR CORD (SAME LENGTH AS FLEX LINES)

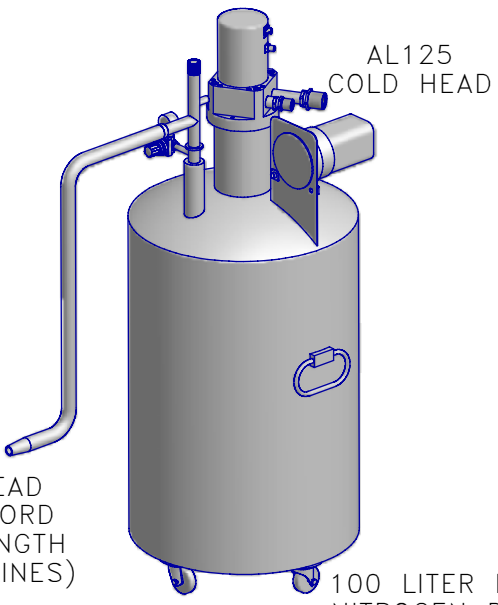
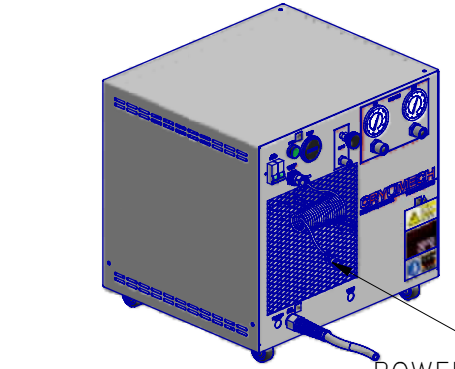
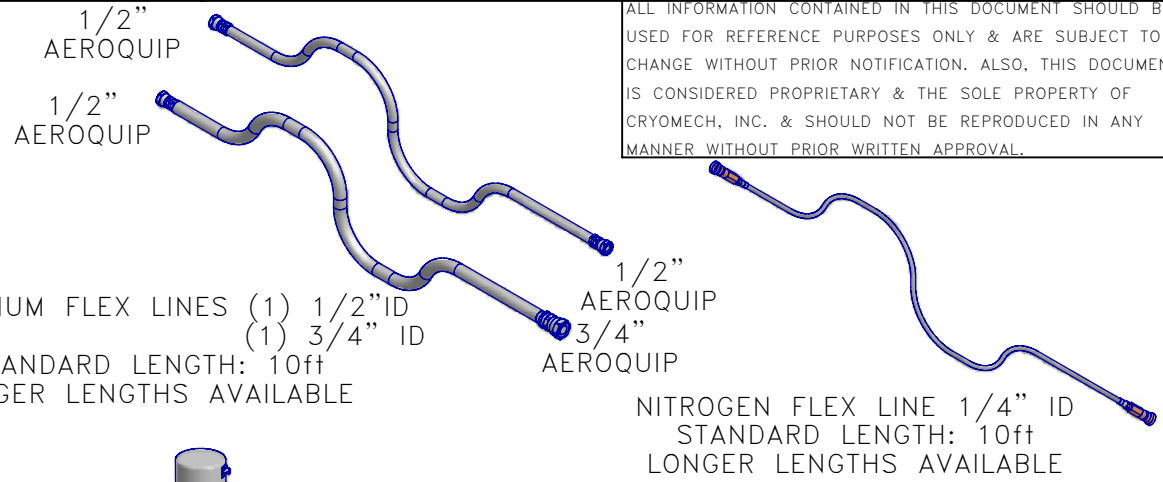
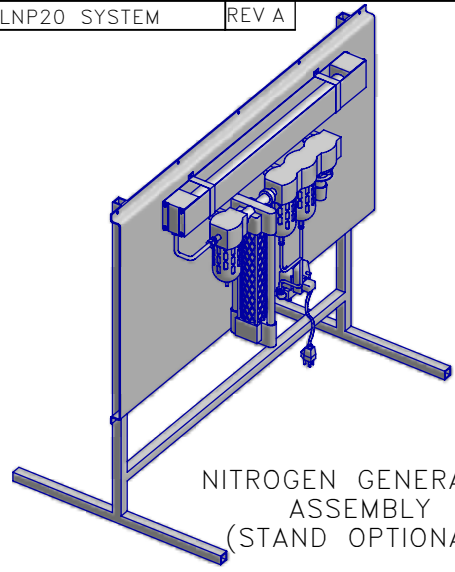
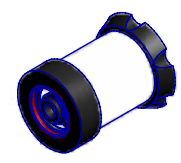
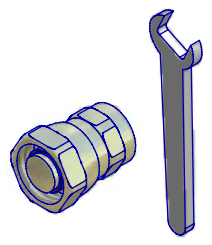
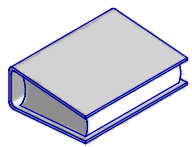
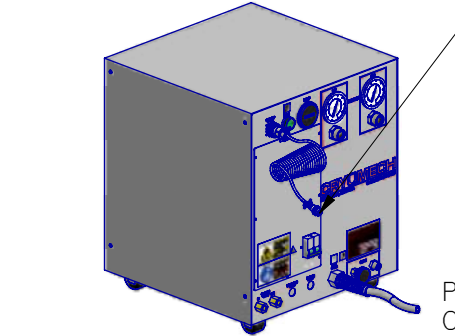

THIRD ANGLE PROJECTION

**CRYOMECH, INC**  
113 FALSO DRIVE SYRACUSE N.Y. 13211  
Tel: (315)455-2555 Fax: (315)455-2544

ALL DIMENSIONS ARE IN INCHES  
TOLERANCES: FRACTIONS ±1/64 DECIMALS XXX=±.005 XX=±.01 X=±.1  
ANGLES ±.5° ALLOVER FINISH 25 R<sub>a</sub>  
CONCENTRICITY .005 TOTAL INDICATOR RUN OUT  
PERPENDICULARITY ±.002 (UNLESS OTHERWISE SPECIFIED)

NAME: LNP20 LIQUID NITROGEN PLANT  
PART #: LNP20 SYSTEM SHT 1 OF 1  
MATERIAL: AS STATED

1419	-	A	SEE ECN 1419	03JUL07
613	-	-	INITIAL RELEASE	18AUG04
ECN	ZONE	REV	DESCRIPTION	DATE

DWN BY: BL	DATE: 18AUG04	SCALE: TO FIT	DWG SIZE: A
1ST CHK: RED	DATE: 26AUG04	2ND CHK: NLO	DATE: 26AUG04
CUST: -			