

ALL INFORMATION CONTAINED IN THIS DOCUMENT SHOULD BE USED FOR REFERENCE PURPOSES ONLY & ARE SUBJECT TO CHANGE WITHOUT PRIOR NOTIFICATION. ALSO, THIS DOCUMENT IS CONSIDERED PROPRIETARY & THE SOLE PROPERTY OF CRYOMECH, INC. & SHOULD NOT BE REPRODUCED IN ANY MANNER WITHOUT PRIOR WRITTEN APPROVAL.

B

B

A

A

A

A

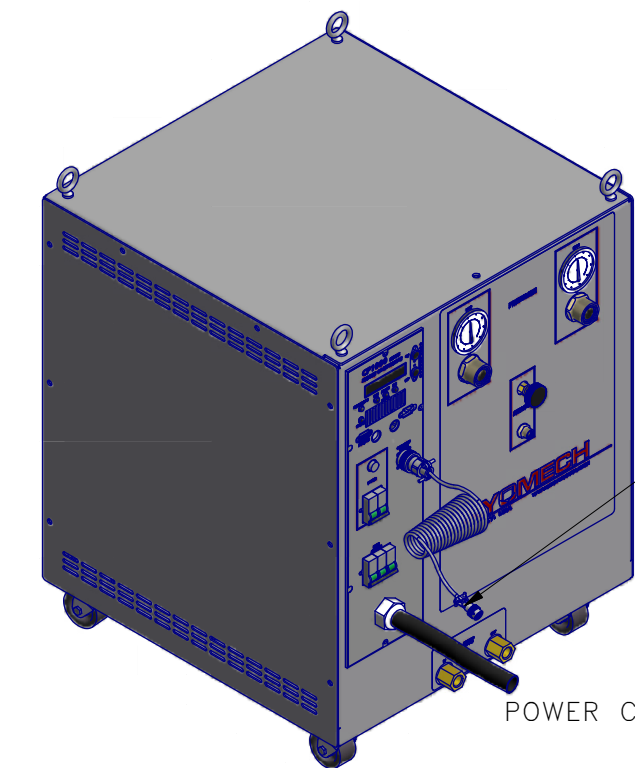

3/4" AEROQUIP

3/4" AEROQUIP

(2) LOW NOISE HELIUM FLEX LINES 1" ID
STANDARD LENGTH: 66 ft
LONGER LENGTHS AVAILABLE

3/4" AEROQUIP

3/4" AEROQUIP

COLD HEAD MOTOR CORD (SAME LENGTH AS FLEX LINES)

POWER CORD

MANUAL

TOOL KIT

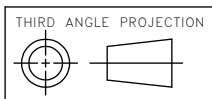
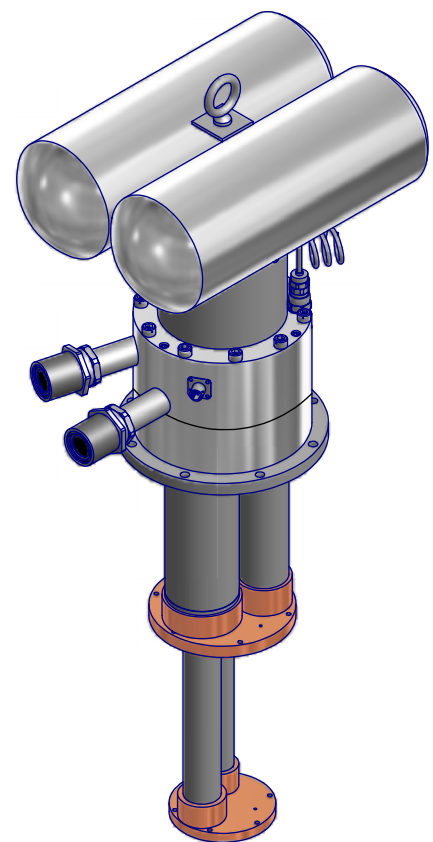

CRYOMECH, INC
113 FALSO DRIVE SYRACUSE, N.Y. 13211
Tel: (315)455-2555 Fax:(315)455-2544

ALL DIMENSIONS ARE IN INCHES
TOLERANCES: FRACTIONS ±1/32 DECIMALS XXX=±.005 XX =±.01
ANGLES ±.5° ALLOVER FINISH 25 Ra
CONCENTRICITY .005 TOTAL INDICATOR RUN OUT
PERPENDICULAR ±.002 (UNLESS OTHERWISE SPECIFIED)

NAME: PT415 CP1110 CRYOREFRIGERATOR			
DWG #: PT415 CP1110 SYSTEM		SHT 1 OF 1	
MATERIAL: AS STATED			
DWN BY: BMR		DATE: 13JUN11	SCALE: TO FIT
1ST CHK: BS		DATE: 17JUN11	2ND CHK: PB
CUST:		DATE: 17JUN11	
		BTA:	

2630	-	-	INITIAL RELEASE	13JUN11
ECN	ZONE	REV	DESCRIPTION	DATE

2

1