

ALL INFORMATION CONTAINED IN THIS DOCUMENT SHOULD BE USED FOR REFERENCE PURPOSES ONLY & ARE SUBJECT TO CHANGE WITHOUT PRIOR NOTIFICATION. ALSO, THIS DOCUMENT IS CONSIDERED PROPRIETARY & THE SOLE PROPERTY OF CRYOMECH, INC. & SHOULD NOT BE REPRODUCED IN ANY MANNER WITHOUT PRIOR WRITTEN APPROVAL.

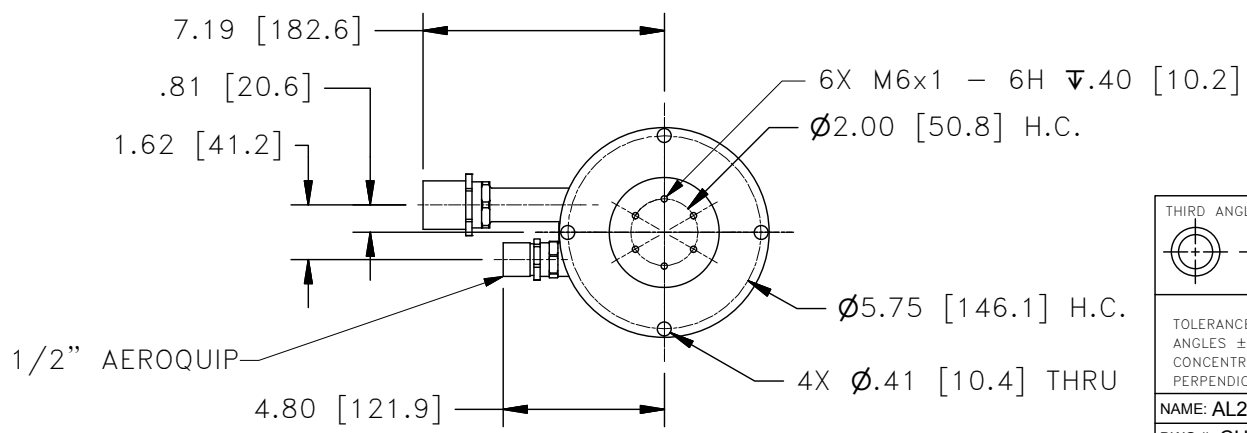
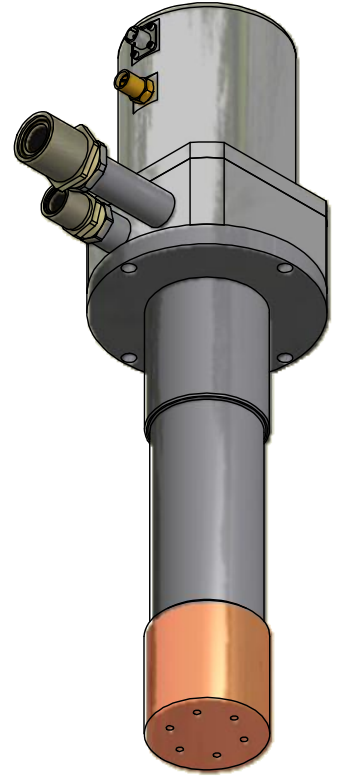
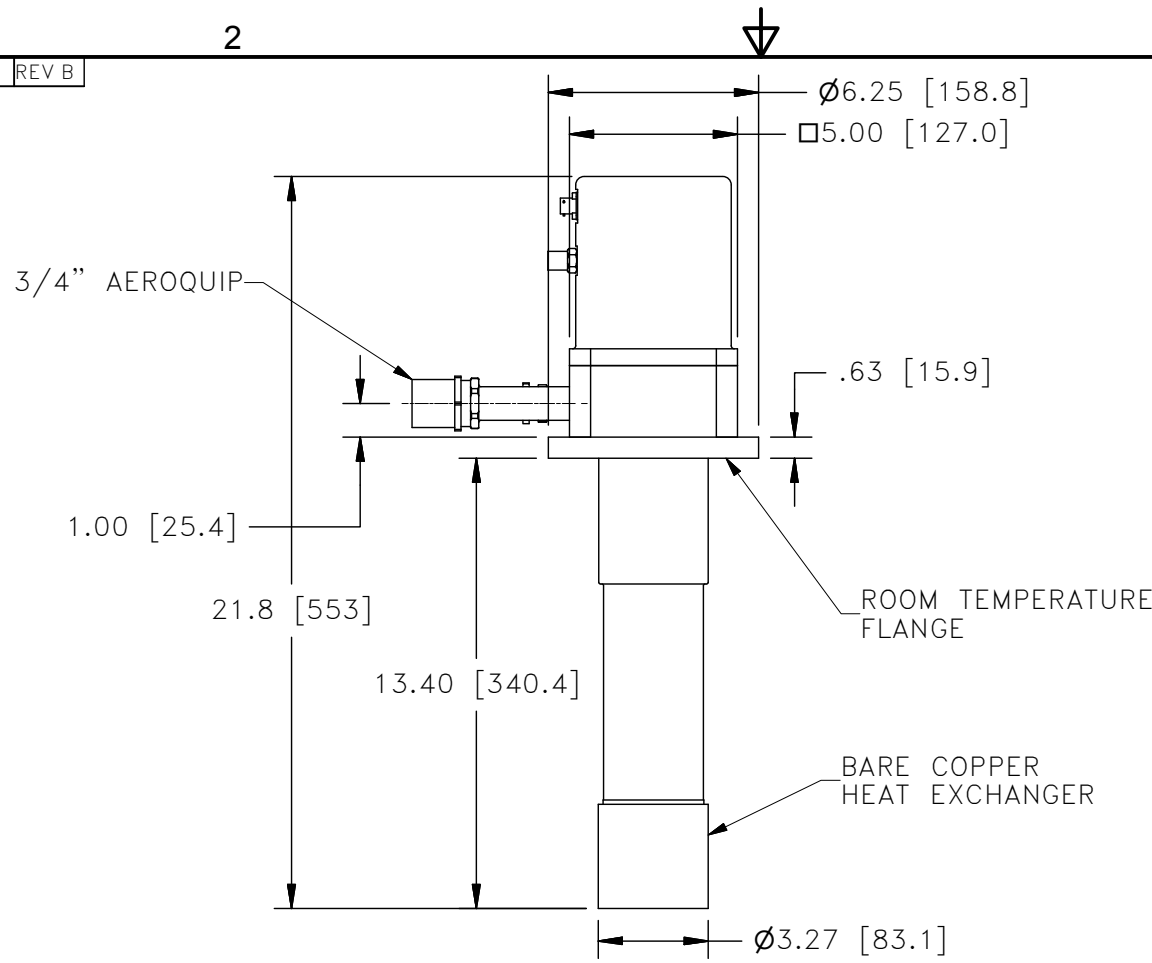

THIRD ANGLE PROJECTION

CRYOMECH, INC
 113 FALSO DRIVE SYRACUSE, N.Y. 13211
 Tel: (315)455-2555 Fax:(315)455-2544

ALL DIMENSIONS ARE IN INCHES
 TOLERANCES: FRACTIONS $\pm 1/32$ DECIMALS $XXX = \pm .005$ $XX = \pm .01$
 ANGLES $\pm .5^\circ$ ALLOVER FINISH 25 Ra
 CONCENTRICITY .005 TOTAL INDICATOR RUN OUT
 PERPENDICULAR $\pm .002$ (UNLESS OTHERWISE SPECIFIED)

NAME: AL230 COLDHEAD OUTLINE
 DWG #: CH1A230 SHT 1 OF 1
 MATERIAL: 103-09
 DWN BY: BMR DATE: 13NOV07 SCALE: .175 DWG SIZE: A
 1ST CHK: AO DATE: 27NOV07 2ND CHK: NLO DATE: 27NOV07
 CUST: BTA: BTA-CH1A230

ECN	ZONE	REV	DESCRIPTION	DATE
2511	-	B	REMOVED PLATING	10AUG10
1900	A2	A	CHANGED NICKEL PLATING SPEC.	06JUL09
1499	-	-	INITIAL RELEASE	13NOV07