

ALL INFORMATION CONTAINED IN THIS DOCUMENT SHOULD BE USED FOR REFERENCE PURPOSES ONLY & ARE SUBJECT TO CHANGE WITHOUT PRIOR NOTIFICATION. ALSO, THIS DOCUMENT IS CONSIDERED PROPRIETARY & THE SOLE PROPERTY OF CRYOMECH, INC. & SHOULD NOT BE REPRODUCED IN ANY MANNER WITHOUT PRIOR WRITTEN APPROVAL.

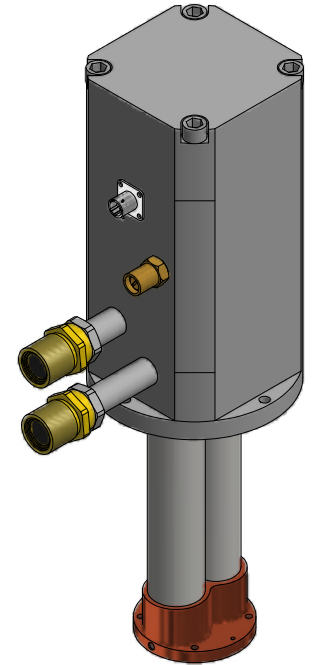

POWER CORD
CP830 COMPRESSOR PACKAGE
(AIR COOLED)

COLD HEAD
MOTOR CORD
(SAME LENGTH
AS FLEX LINES)

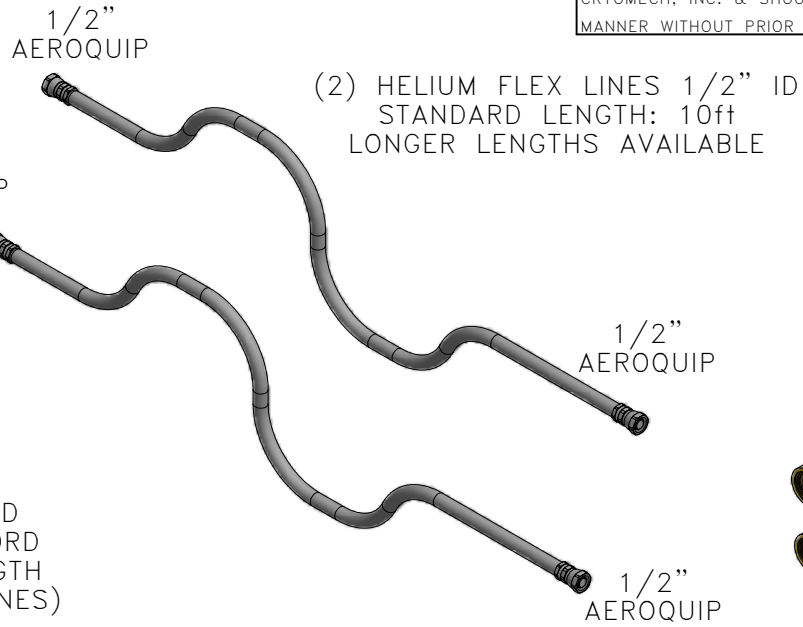

PT63 COLD HEAD



POWER CORD
CP830 COMPRESSOR PACKAGE
(WATER COOLED)

MANUAL

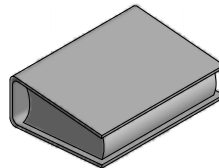

TOOL KIT

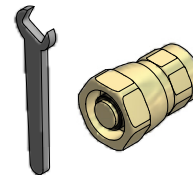

THIRD ANGLE PROJECTION		CRYOMECH, INC	
		113 FALSO DRIVE SYRACUSE, N.Y. 13211 Tel: (315)455-2555 Fax:(315)455-2544	
ALL DIMENSIONS ARE IN INCHES			
TOLERANCES: FRACTIONS ±1/32 DECIMALS .XXX=±.005 .XX =±.01 .X=±.1			
ANGLES ±.5° ALLOVER FINISH 25 Ra			
CONCENTRICITY .005 TOTAL INDICATOR RUN OUT			
PERPENDICULAR ±.002 (UNLESS OTHERWISE SPECIFIED)			
NAME: PT63 SYSTEM DRAWING			
DWG #: PT63 SYSTEM		SHT 1 OF 1	
MATERIAL: AS STATED			
DWN BY: BMR		DATE: 26SEP06	SCALE: TO FIT
DWN SIZE: A	1ST CHK: AO	DATE: 11JUL07	2ND CHK: NLO
DATE: 11JUL07	DATE: 11JUL07	DATE: 11JUL07	DATE: 11JUL07
CUST: -		BTA: -	

1419	-	-	INITIAL RELEASE	03JUL07
ECN	ZONE	REV	DESCRIPTION	DATE